

LOC	DIST	REVISIONS					
G	14	P	LTR	DESCRIPTION	DATE	DWN	APVD
			K7	REVISED PER ECO-11-013501	30JUN11	HMR	DR

**AMP**  
 WIRE RANGE  
 6 AWG  
 SOLID OR STRANDED

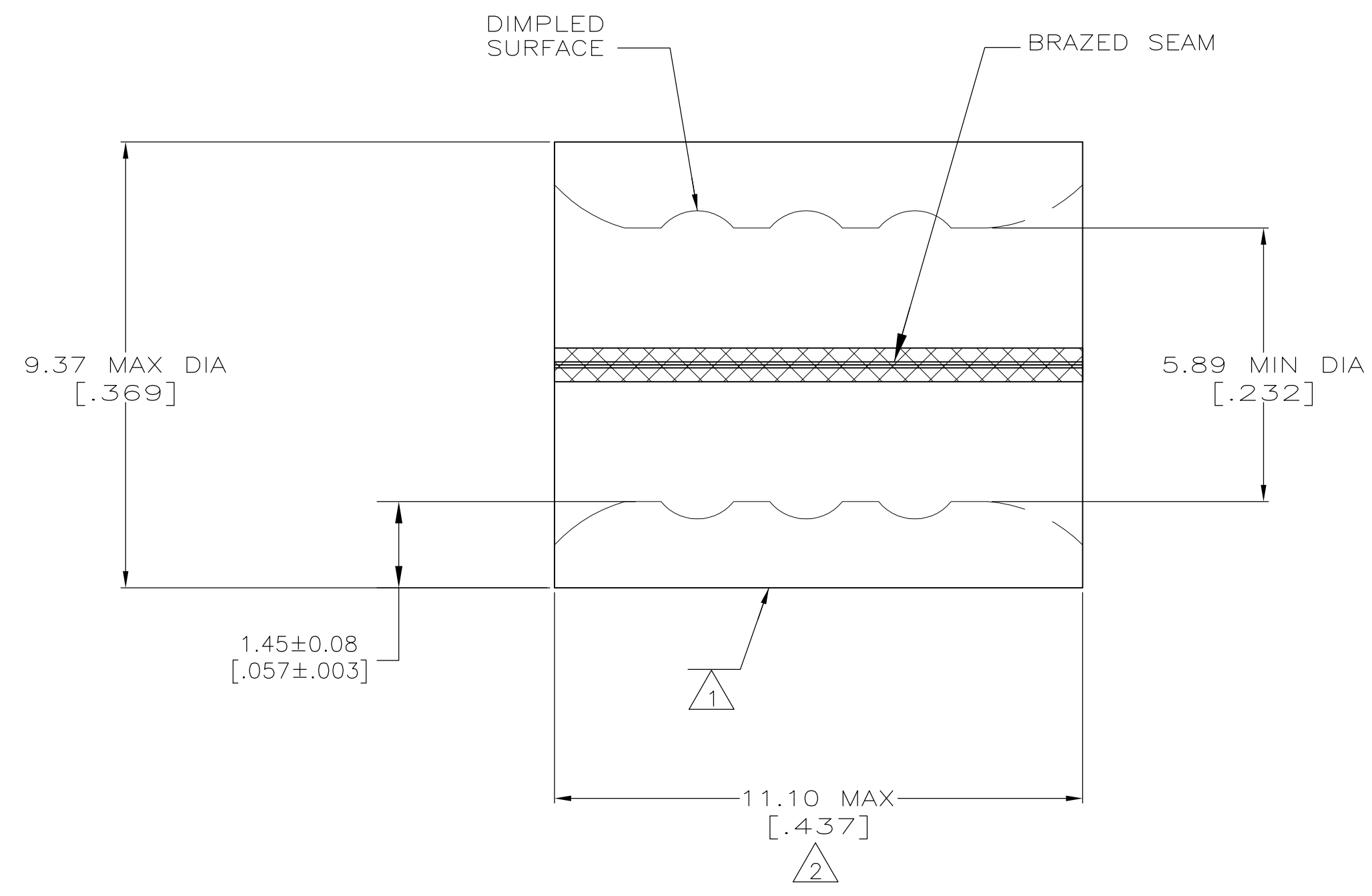

- 1 STAMP AMP 6W\* APPROX AS SHOWN
- 2 MAXIMUM LENGTH DOES NOT INCLUDE MANUFACTURING TABS
- 3 MATERIAL: COPPER PER ASTM B-152 ANNEALED
- 4 UL LISTED E13288, 6 AWG STRANDED
- 5 CSA CERTIFIED LR7189, 6 AWG SOLID OR STRANDED.
- 6 0.00254 [.000100] MIN TIN ASTM B-545
- 7 TIN/LEAD (60/40) 0.00254 [.000100] MIN TIN SAE-AMS-P-81728
- 8 GOLD PLATE 0.00127[.000050] MIN EXT THK PER ASTM B488, TYPE 1, CODE C OVER NICKEL PLATE 0.00127[.000050] MIN EXT THK PER SAE AMS QQ-N-290 OVER Cu FLASH PER SAE AMS 2418
- 9 NOTE DELETED.

170°C[338°F]	4 5	20	6	LOOSE PIECE, BOX	8-34319-5
260°C[500°F]	----	100	8	LOOSE PIECE	34319-3
170°C[338°F]	----	100	7	LOOSE PIECE	34319-1
170°C[338°F]	4 5	500	6	LOOSE PIECE	34319
MAX OPERATING TEMP	APPROVALS	QTY	FINISH	PACKAGE TYPE	PART NO

<b>AMP INCORPORATED CUSTOMER SERVICE SYSTEMS</b>		MAX RECOMMENDED OPERATING TEMPERATURE: SEE TABLE
FOR ADDITIONAL PRODUCT INFORMATION OR COPIES OF DRAWINGS AND TECHNICAL DOCUMENTS	PRODUCT INFORMATION CENTER 1-800-522-6752	VOLTAGE RATING: N/A
FOR APPLICATION TOOLING INFORMATION	TOOLING ASSISTANCE CENTER 1-800-722-1111	CIRCULAR MIL AREA: 10.5-16.8mm <sup>2</sup> [20,800-33,100] SOLID OR STRANDED
FOR ORDER ENTRY	1-800-526-5142	THIS DRAWING IS A CONTROLLED DOCUMENT FOR AMP INCORPORATED. IT IS SUBJECT TO CHANGE AND THE CONTROLLING ENGINEERING ORGANIZATION SHOULD BE CONTACTED FOR THE LATEST REVISION.

THIS DRAWING IS A CONTROLLED DOCUMENT.		DWN TA BRINKMAN 4-14-93	<b>STE</b> TE Connectivity	
DIMENSIONS: mm[INCHES]		CHK DA PATTERSON 4-14-93		
TOLERANCES UNLESS OTHERWISE SPECIFIED:		APVD DA PATTERSON 4-14-93	NAME SPLICE, PARALLEL, SOLISTRAND	
0 PLC ± - 1 PLC ± - 2 PLC ± - 3 PLC ± - 4 PLC ± - ANGLES ± ± -		PRODUCT SPEC -	SIZE A2	
MATERIAL 3		FINISH SEE TABLE	CAGE CODE 00779	DRAWING NO G-34319
		WEIGHT -	RESTRICTED TO -	
		CUSTOMER DRAWING		SCALE 10:1 SHEET 1 OF 1 REV K7